

Two-bearing housings

PD series

Bearing types

- Single row deep groove ball bearings
- Single row angular contact ball bearings
- Single row cylindrical roller bearings

Bearing dimension series

- 62, 63
- 72, 73
- NU 22, NU 3, NJ 22, NJ 23, NJ 2, NJ 3

Shaft diameter range

- 25 to 120 mm

Shaft-bearing combination

- On a stepped shaft with bearings on a cylindrical seat

Seals

- Felt strip
- V-ring

Lubrication

- Grease
- Oil lubrication (optional)

Materials

- Grey cast iron

Mounting

- Four-bolt mounting

Compliance to standards

- Not standardized

SKF two-bearing housings were originally developed for fan shafts with an overhung impeller, but are also suitable for other applications with similar shaft arrangements.

Compared to the conventional shaft arrangement where two self-aligning bearings are mounted in separate plummer (pillow) block housings, two-bearing housings provide several advantages including improved running accuracy and quieter operation.

PD two-bearing housings can also be supplied as ready-to-mount units.

Two-bearing housings

PD series

Designations	555	Product tables	
Standard housing design	557	12.1 Two-bearing housings in the PDN series	572
Features and benefits	557	12.2 Two-bearing housings in the PDP series	576
Housing material	557	12.3 Two-bearing housings in the PDR series	578
Paint, corrosion protection	557	12.4 Shafts for two-bearing housings in the PDN 2 series	580
Dimension standards	557	12.5 Shafts for two-bearing housings in the PDN 3 series	582
Housing variants	558	12.6 Shafts for two-bearing housings in the PDP series	584
Sealing solutions	558	12.7 Shafts for two-bearing housings in the PDR series	586
Design considerations	560		
Shaft-bearing combinations	560		
Standard bearing arrangements ...	560		
Non-standard bearing arrangements	562		
Bearing arrangements	564		
Load carrying capacity	564		
Operating temperature	564		
Operating speed	564		
Shaft specifications	564		
Attachment bolt recommendations ...	566		
Lubrication	567		
Flinger rings	567		
Initial grease fill	567		
Relubrication	567		
Oil lubrication	567		
Mounting	568		
Mounting PDN series housing	568		
Mounting PD units	568		
Condition monitoring	569		
Accessories	569		
Ordering information	570		
PD two-bearing housings	570		
PD two-bearing units	570		

Designations

Designation system for PD two-bearing housings

PDR 319

Series

PDN	Housing for normal radial and axial loads
PDP	Housing for predominant or alternating axial loads
PDR	Housing for heavy radial loads

Size identification

2(00)	Housing for bearings in the 62, 72, NU 2, NJ 2, NJ 22, NJ 23, 222 and 223 series
3(00)	Housing for bearings in the 63, 73, NU 3 and NJ 3 series
..(00)	Size code of the bearings, (00) × 5 = bearing bore diameter [mm]

Designation system for shafts

VJ-PDPF 218

Prefix

VJ-	Shaft for two-bearing housings
------------	--------------------------------

Series

PDNB	For housings in the PDN series
PDPF	For housings in the PDP series
PDRJ	For housings in the PDR series

Size identification

...	Size identification of the housing
------------	------------------------------------

Two-bearing housings PD series

Designation system for PD two-bearing units

PDPF 220
PDNB 305 DD

Housing series

PDN	Housing for normal radial and axial loads
PDP	Housing for predominant or alternating axial loads
PDR	Housing for heavy radial loads

Size identification

	Non-locating bearing position	Locating bearing position	Housing series
A	Deep groove ball bearing	Two angular contact ball bearings	PDN
B ¹⁾	Deep groove ball bearing	Deep groove ball bearing	PDN
D	Cylindrical roller bearing	Cylindrical roller bearing	PDN
E	Cylindrical roller bearing	Deep groove ball bearing	PDN
F ¹⁾	Cylindrical roller bearing	Two angular contact ball bearings	PDN, PDP
J ¹⁾	Cylindrical roller bearing	Cylindrical roller bearing + Deep groove ball bearing	PDR
L	Spherical roller bearing	Spherical roller bearing	PDN

Size identification

2(00)	Housing for bearings in the 62, 72, NU 2, NJ 2, NJ 22, NJ 23, 222 and 223 series
3(00)	Housing for bearings in the 63, 73, NU 3 and NJ 3 series
..(00)	Size code of the bearings, (00) x 5 = bearing bore diameter [mm]

Suffixes

DD	Unit supplied with shaft spacers and a large bore in the covers at both sides
U	Unit supplied without shaft spacers (PDP and PDR units only)

¹⁾ Standard units include PDNB, PDPF and PDRJ

Fig. 1

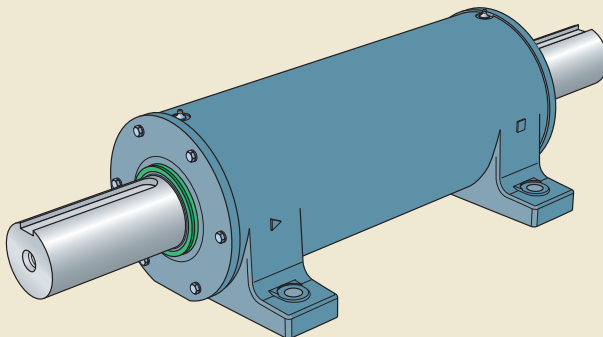

Standard housing design

PD two-bearing housings are non-split housings with two bearing seats (→ **fig. 1**). They consist of a housing body and two covers that are bolted to the body with either four or six bolts. The housings have four holes drilled into the feet for attachment bolts.

PD housings are available in three series, each similar in their external design, but accommodating different bearing arrangements:

- PDN series, for normal radial and axial loads
- PDP series, for predominant or alternating axial loads
- PDR series, for heavy radial and normal axial loads

Features and benefits

PD housings have the following features and benefits:

Compact design

The bearings are incorporated in one housing, which saves space.

Smooth running

The two bearing seats are concentric. Since bearing misalignment is avoided, rigid bearings can be used. The resulting stiff arrangement provides a high degree of running accuracy and enables high speeds.

Quiet operation

The accurate alignment of the rigid bearings in one housing enables quiet operation. For units with the designation PDNB, a wave spring washer in the smaller housing range further reduces noise levels.

Available as units

PD housings can also be supplied as units, complete with bearings and shaft. These ready-to-mount units are assembled and greased at the factory, saving time and reducing the risk of contaminating or damaging the bearings during assembly.

Easy handling

Large housings have two eye bolts for safe and easy handling.

Housing material

PD two-bearing housings and their covers are made of grey cast iron.

Paint, corrosion protection

PD housings are painted blue (RAL 5007) using a solvent based alkyd paint. The paint protects the housing in accordance with ISO 12944-2, corrosivity category C2 (i.e. exterior atmospheres with low levels of pollution, interior atmospheres where condensation may occur). The paint is not affected by most lubricating or engine oils, cutting fluids or alkaline washing chemicals. Housings can be repainted with most water or solvent based 1- or 2-component paints.

Unpainted surfaces are protected with a solventless rust inhibitor.

Dimension standards

The dimensions of PD two-bearing housings are not standardized either nationally or internationally.

Housing variants

In addition to standard design PD housings, the following variants are available on request:

- housings for oil bath or circulating oil lubrication systems
- housings for vertical shaft arrangements

For additional information, contact the SKF application engineering service.

Sealing solutions

PD two-bearing housings are designed for two sealing solutions:

- a V-ring seal, for housings in the PDN 2 and PDP series (→ **fig. 2**)
- a felt strip and a V-ring seal, for housings in the PDN 3 and PDR series (→ **fig. 3**)

Table 1, provides an overview of the properties and suitability of each sealing solution. This information should be used as a guideline, which cannot substitute for testing the seal in its application.

Housings in the PDN 3 and PDR series have felt strips, which are mounted in a groove in the cover. At circumferential speeds above 4 m/s, a small gap forms between the felt and the seal counterface.

The outboard V-ring seals (for all housing series) provide additional protection against contaminants. They can accommodate circumferential speeds up to 7 m/s.

PD housings are supplied with seals but the seals can also be ordered separately.

Fig. 2

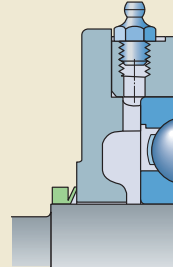

Fig. 3

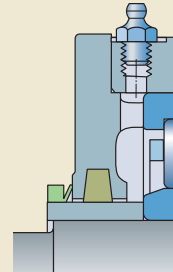
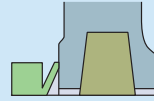

Table 1

Standard seals for PD two-bearing housings

**Seal**

Type	V-ring seal	Felt strip and V-ring seal
Housing series	PDN 2, PDP	PDN 3, PDR
Material	nitrile rubber	felt, nitrile rubber

Application conditions and requirements

Temperature [°C]	-40 to +100	-40 to +100
Temperature [°F]	-40 to +210	-40 to +210
Max. circumferential speed ¹⁾ [m/s]	7 ²⁾	4 ³⁾
Low friction	++	-
Shaft tolerance class	→ page 564	→ page 564
Shaft roughness R_a [μm]	3,2	3,2

Sealing suitability

Dust	+	+
Fine particles	+	+
Coarse particles	+	+
Chips	--	+
Liquids when sprayed	+	+
Direct sunlight	--	+

Symbol: ++ very suitable
 + suitable
 - limited suitability
 -- unsuitable

¹⁾ To convert circumferential speeds to rotational speeds, refer to **table 7** on **page 37**.

²⁾ If located axially, higher speeds are possible.

³⁾ At higher speeds, a small gap forms between the felt and the shaft.

Design considerations

For general information about system design, refer to the following sections:

- *Shaft seat tolerances* (→ skf.com/bearings)
- *Load carrying capacity* (→ [page 44](#))
- *Specifications for shafts and housing support surfaces* (→ [page 45](#))

For additional information about rolling bearings, refer to the product information available online at skf.com/bearings.

Shaft-bearing combinations

PD two-bearing housings accommodate bearings on a cylindrical seat on stepped shafts.

Standard bearing arrangements

PD two-bearing housings can accommodate different bearing arrangements, depending on the series.

Housings in the PDN series

The bearing arrangement for housings in the PDN series comprises:

- two single row deep groove ball bearings in the 62 series for housings in the PDN 2 series (→ [fig. 4](#))
- two single row deep groove ball bearings in the 63 series for housings in the PDN 3 series (→ [fig. 5](#))

The bearing arrangements are intended for normal load conditions and relatively high speed operation. The arrangement for housings in the PDN 3 series can accommodate heavier loads than PDN 2 series housings.

A wave spring washer, supplied with housings up to size 218 or 316, preloads the bearings against each other to reduce noise levels. Units with spring-loaded bearings can accommodate axial loads in one direction only (→ [Mounting, page 568](#)).

Housings in the PDN series can also be used for other bearing combinations (→ *Non-standard bearing arrangements, page 562*).

Housings in the PDP series

The bearing arrangement for housings in the PDP series comprises (→ [fig. 6](#)):

- a single row cylindrical roller bearing in the NU 22 ECP series, in the non-locating bearing position
- a pair of universally matchable single row angular contact ball bearings in the 72 series, mounted back-to-back in the locating bearing position

This bearing arrangement accommodates axial loads in both directions and can support heavier loads than bearings in PDN series housings.

Housings in the PDP series can also accommodate other bearing combinations.

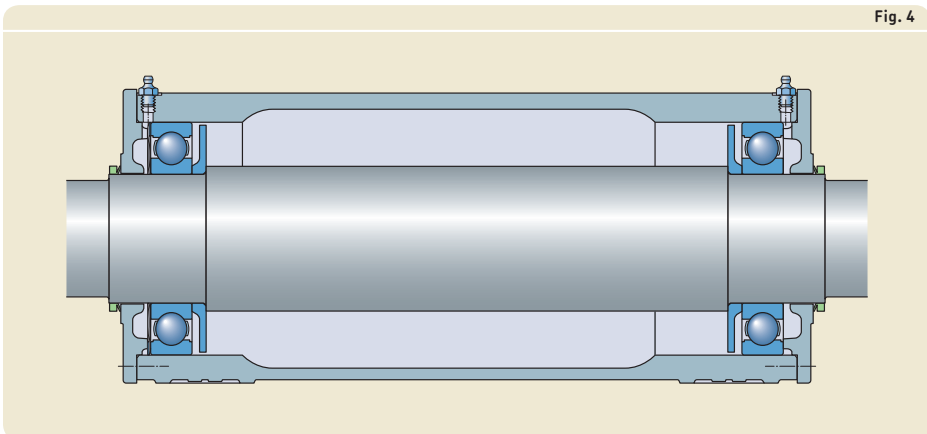

Fig. 5

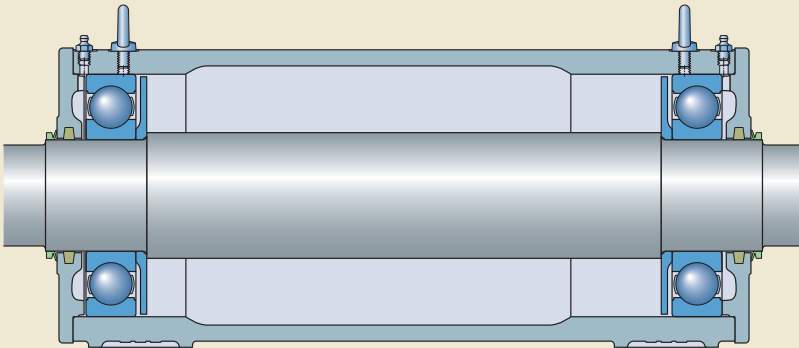

Fig. 6



Two-bearing housings PD series

Housings in the PDR series

The bearing arrangement for housings in the PDR series comprises (→ **fig. 7**):

- a single row cylindrical roller bearing in the NU 3 ECP series, in the non-locating bearing position
- a cylindrical roller bearing in the NU 3 ECP series in combination with a single row deep groove ball bearing in the 63 series (with C3 clearance), in the locating bearing position

The deep groove ball bearing acts as a pure thrust bearing, accommodating the axial loads in both directions, and is mounted with radial clearance in the housing. To prevent the outer ring from turning, an O-ring is inserted in a groove in the cover that abuts the outer ring.

The bearings support heavier radial loads than bearings in both PDN and PDP series housings.

Non-standard bearing arrangements

Housings in the PDN series are designed to accommodate two deep groove ball bearings. For special applications, the housings can be fitted with various combinations of deep groove ball bearings, angular contact ball bearings, cylindrical roller bearings and spherical roller bearings.

SKF can supply the following combinations, available as assembled units (→ **fig. 8**):

- PDNA .. DD units, incorporating a deep groove ball bearing in the non-locating bearing position and a pair of universally matchable angular contact ball bearings, mounted back-to-back, in the locating bearing position. Smaller housings accommodate axial loads in only one direction, while larger housings can withstand axial loads in both directions (**a**)
- PDND units, incorporating an NJ design cylindrical roller bearing on each end to form a cross-located ("floating") bearing arrangement (**b**)
- PDNE units, an NJ design cylindrical roller bearing and a deep groove ball bearing to form a cross-located ("floating") bearing arrangement (**c**)
- PDNF .. DD units, incorporating an NJ design cylindrical roller bearing and a pair of universally matchable angular contact ball bearings, mounted back-to-back, to form a cross-located ("floating") bearing arrangement (**d**)
- PDNL units, incorporating a spherical roller bearing on each end to form a cross-located ("floating") bearing arrangement (**e**)

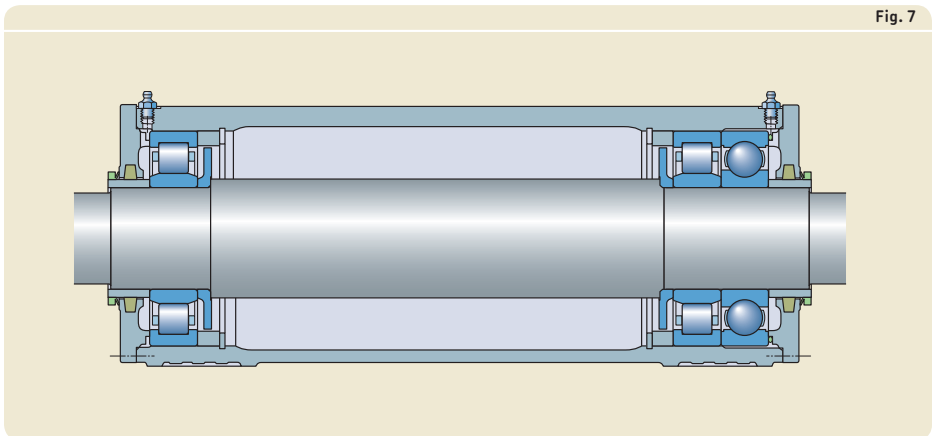
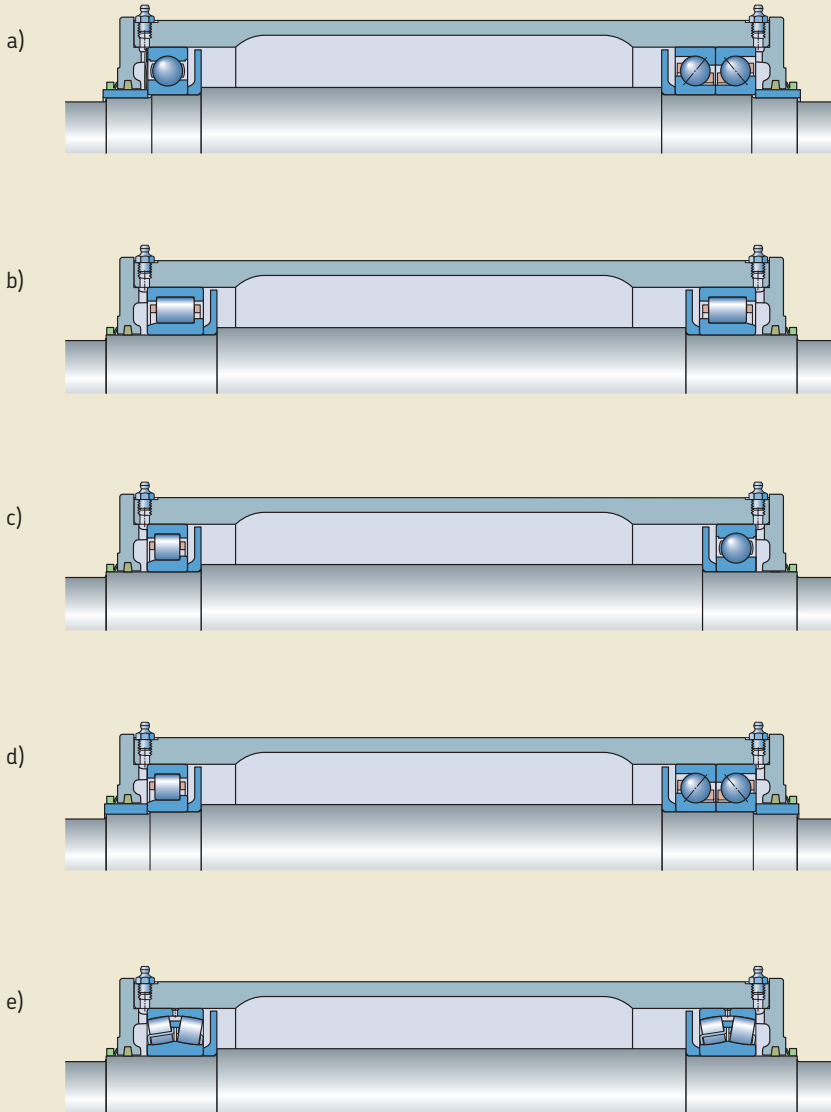

Fig. 7

Fig. 8



Two-bearing housings PD series

Bearing arrangements

Typically, PD two-bearing housings accommodate a locating and a non-locating bearing. In some applications, however, both bearings are used to locate the shaft axially, each in one direction. This is called a cross-located (“floating”) bearing arrangement.

Load carrying capacity

PD two-bearing housings are intended for loads acting perpendicularly toward the support surface. If the housing is supported over its four feet and the loads are purely perpendicular, loads are limited only by the bearings.

Housings in the PDN series that have bearings preloaded with a wave spring washer accommodate axial loads in one direction only.

Operating temperature

The permissible operating temperature is mainly limited by the seals and lubricant. For temperature limits of SKF bearings and lubricants, refer to the product information available online at skf.com/bearings. For temperature limits of the seals used in PD housings, refer to **table 1** on **page 559**.

The housing material does not set any additional temperature limits, except for very low temperature applications where impact strength could be a factor.

The housing paint is heat resistant up to 80 °C (175 °F) material temperature or 100 °C (210 °F) ambient temperature.

When temperatures outside the permissible range are expected, contact the SKF application engineering service.

Operating speed

The permissible operating speed of the incorporated bearings is limited by the V-ring and felt seals, but not by the housing. Speed limits of the seals are listed in **table 1** on **page 559**.

Shaft specifications

Shafts for two-bearing housings can be machined according to the recommended dimensions provided in **product tables 13.4** to **13.7**. The bearing seats should be machined to the tolerance classes listed in **table 2**. The

accuracy of form should be to tolerance grade IT5 for shaft diameters up to and including 60 mm and IT6 for larger diameter shafts. At the seal position, the shaft (or shaft sleeve) should comply with the same tolerance classes as the bearing seat.

SKF also supplies pre-machined shafts to fit PD housings. Their designations are provided in the product tables. The bearing seats and shaft ends are machined to the tolerance classes listed in **table 2** and **table 3** respectively.

Shafts are supplied with two keys and two end plates with attachment screws.

Table 2

Bearing seat tolerance classes

Shaft diameter d_a		Tolerance class ¹⁾ for housing series PDN	PDP with angular contact ball bearings	cylindrical roller bearings	PDR
over	incl.				
mm		–			
– 100	100 –	k6 k6	k6 m6	m6 m6	m6 m6

¹⁾ The recommended tolerance classes are intended for light loaded bearings only ($P < 0,05 C$, see also skf.com/bearings). Tighter fits are required for heavier loads. For additional information, contact the SKF application engineering service.

Table 3

Shaft end specifications

Shaft end diameter d_b		Tolerance class for housing series		
over	incl.	PDN	PDP	PDR
mm		–		
– 30 50	30 50 110	j6 k6 m6	m6 m6 m6	m6 m6 m6

Attachment bolt recommendations

In typical applications, 8.8 class hexagon head bolts in accordance with ISO 4014 can be used together with washers. If loads do not act perpendicularly towards the support surface, it may be necessary to use stronger, 10.9 class bolts.

SKF housings can withstand loads resulting from tightening the attachment bolts to the values recommended by bolt manufacturers (→ **table 4**). They are valid for oiled, but otherwise untreated thread surfaces. SKF cannot confirm that tightening to the recommended value will provide sufficient anchoring. Make sure that attachment bolts and a sufficiently strong support can accommodate all occurring loads.

Table 4

Cover bolts and attachment bolts							
Housing series				Cover bolts		Attachment bolts	
PDN 2	PDN 3	PDP	PDR	Size	Tightening torque	Size	Tightening torque ¹⁾
–				–	Nm	–	Nm
PDN 206	PDN 305			M 6x20	10	M 10	50
PDN 207	PDN 306			M 6x20	10	M 12	80
PDN 208	PDN 307			M 6x20	10	M 12	80
PDN 210	PDN 308			M 6x20	10	M 12	80
PDN 211	PDN 309			M 6x20	10	M 12	80
PDN 212	PDN 310			M 6x20	10	M 12	80
PDN 214	PDN 311			M 8x25	25	M 16	200
PDN 215	PDN 312	PDP 2214		M 8x25	25	M 16	200
PDN 216	PDN 313	PDP 2216		M 8x25	25	M 16	200
	PDN 314			M 8x25	25	M 16	200
PDN 218	PDN 315	PDP 2218	PDR 315	M 8x30	25	M 16	200
	PDN 316		PDR 316	M 10x30	50	M 16	200
PDN 220	PDN 317	PDP 2220	PDR 317	M 10x30	50	M 16	200
	PDN 318		PDR 318	M 10x30	50	M 16	200
PDN 222	PDN 319	PDP 2222	PDR 319	M 10x35	50	M 20	385
PDN 224	PDN 320	PDP 2224	PDR 320	M 12x35	80	M 20	385
	PDN 322		PDR 322	M 12x35	80	M 24	665
	PDN 324		PDR 324	M 12x35	80	M 30	1310

¹⁾ Recommended by bolt manufacturers.

Lubrication

Standard PD two-bearing housings are designed for grease lubrication. Housings for oil lubrication are available on request.

The lubricant should be selected based on the operating conditions of the bearings. For additional information about lubricant selection, refer to the product information available online at skf.com.

Flinger rings

PD housings are supplied with inboard flinger rings made of grey cast iron (→ **fig. 9**). The flinger rings serve to retain grease at the bearing position and to prevent over-lubrication. The excess grease is collected in the large space in the middle of the housing.

Initial grease fill

If no other requirements exist, the free space in the bearings should be completely filled with grease and the free space between the cover and flinger ring should be filled to 100%.

Initial grease fill for PD units

PD units are greased at the factory with SKF LGMT 2, a high-quality mineral oil based grease with a lithium thickener and good rust inhibiting properties. The operating temperature range of the grease is -30 to $+110$ °C (-20 to $+230$ °F).

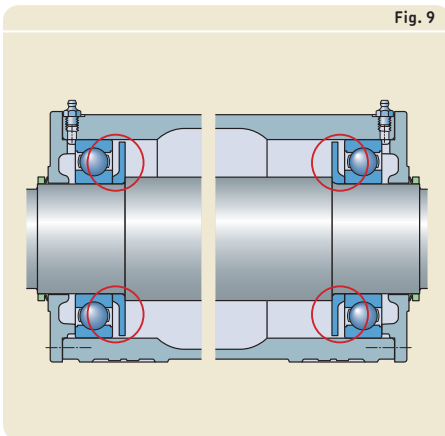

Fig. 9

Relubrication

Relubrication is possible via two G $1/4$ or G $1/8$ grease fittings (depending on size), one on each end of the housing (→ **fig. 10**). There is minimal risk of over-greasing because excess grease is collected in the large space in the middle of the housing. When applying grease via the grease fittings, the shaft should be rotating.

SKF recommends replenishing the housings with SKF LGMT 2, a high-quality mineral oil based grease with a lithium thickener and good rust inhibiting properties. For vertical shaft arrangements, SKF LGMT 3 grease should be used with half the interval required for a similar horizontal application.

To calculate the relubrication interval and the quantity of grease needed for replenishment, refer to the SKF catalogue *Rolling bearings* or skf.com/bearings.

Oil lubrication

Where high speeds preclude the use of grease as a lubricant, large PD housings can be modified for oil bath or circulating oil lubrication systems. The housings are fitted with special oil seals. For additional information, contact the SKF application engineering service.

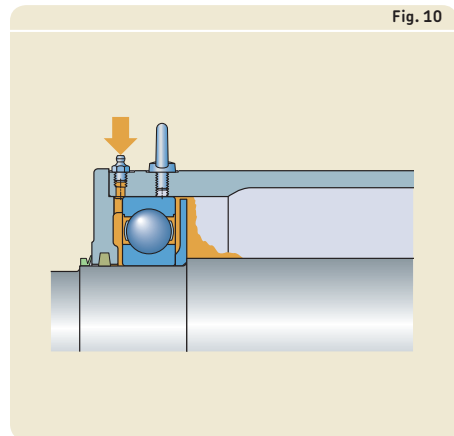

Fig. 10

Mounting

PD housings must be mounted properly, using the correct tools. All the associated components must meet certain basic requirements and the support surface should meet the specifications provided under *Housing support surfaces* (→ page 45).

The housings have two markings (→ fig. 11):

- A “square” on one end denotes the position of the wider of the two bearing seats.
- A “triangle” on the other end indicates the direction in which the predominant axial load should be applied.

For information about mounting rolling bearings, refer to the *SKF bearing maintenance handbook* or skf.com/mount.

Mounting PDN series housings

The wave spring washers, supplied with smaller housings in the PDN series, should be inserted between the bearing and the cover on the housing end marked with a triangle. The rotary components (impeller, pulley, coupling etc.) must be arranged so that the axial load F_a produced in operation acts in the direction indicated by the triangle. SKF recommends using a hydraulic nut or press for these mounting operations.

Mounting PD units

Installing PD units is simple because the unit just needs to be bolted to the support surface. The rotary components are then mounted onto the finished shaft ends secured by the keys, end plates, and attachment screws (with spring washers) provided.

Support the shaft properly when pressing components onto the shaft to prevent the mounting force acting on the bearings. Mounting instructions are available on request.

Torque specifications

Cover bolts should be tightened to the torque values listed in **table 4** on **page 566**. The cover bolts are in accordance with ISO 4017.

For information about attachment bolts, refer to *Attachment bolt recommendations* on **page 566**.

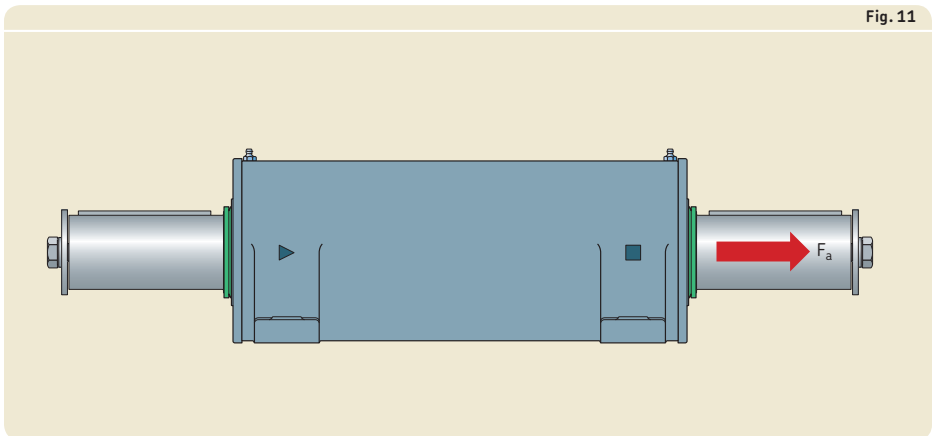

Fig. 11

Condition monitoring

If connections for condition monitoring sensors are required, contact the SKF application engineering service.

Accessories

The following accessories are available for PD two-bearing housings:

- Automatic lubricators: SKF SYSTEM 24 and SKF MultiPoint
- Grease meter: LAGM 1000E

For additional information, refer to *SKF tools and products* (→ **page 47**).

Ordering information

PD two-bearing housings

Housings in the PDN series are supplied with the following components:

- housing
- 2 covers, including 8 or 12 hexagon head bolts and spring washers depending on size
- 2 flinger rings
- 1 wave spring washer (up to and including size 218 for housings in the PDN 2 series, and size 316 for housings in the PDN 3 series)
- 2 seals (V-ring seals for housings in the PDN 2 series; V-ring seals and felt strips for housings in the PDN 3 series)

Housings in the PDP series are supplied with the following components:

- housing, including 2 eye bolts for housings size 224
- 2 covers, including 12 hexagon head bolts and washers
- 2 flinger rings
- 2 locating rings
- 2 spacer sleeves
- 2 shaft sleeves
- 2 V-ring seals

Housings in the PDR series are supplied with the following components:

- housing, including 2 eye bolts for housings from sizes 320 to 324
- 2 covers, including 12 hexagon head bolts and washers
- 2 flinger rings
- 2 spacer sleeves
- 2 shaft sleeves
- 2 seals (V-ring seals and felt strips)
- 1 O-ring

The bearings and shaft must be ordered separately. Shafts are supplied with two keys, and two end plates with attachment screws and spring washers.

Housings in the PDP and PDR series can be supplied without shaft sleeves. They are identified by the designation suffix U, e.g. PDR 315 U.

Order example

One PD housing is required for two 6309 bearings. The following components should be ordered:

- 1 housing PDN 309
- 1 shaft VJ-PDNB 309
- 2 bearings 6309

PD two-bearing units

PD units are supplied assembled and ready-to-mount, complete with bearings and shaft.

Order example

One PD housing is required for two 6309 bearings. The following items should be ordered:

- 1 unit PDNB 309

12.1 Two-bearing housings in the PDN series

d_a 25 – 80 mm

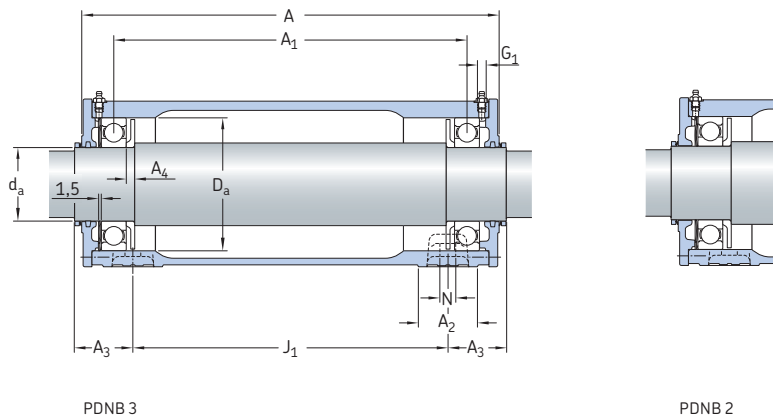

Shaft diameter	Housing Designation ¹⁾	Appropriate parts		Wave spring washer	Spare parts		Unit Designation ¹⁾
		Bearings	Shaft		V-ring	Felt strip	
d_a							
mm	–	–			–		–
25	PDN 305	2 x 6305	VJ-PDNB 305	WF-62	25 VAR	FS 190	PDNB 305
30	PDN 206	2 x 6206	VJ-PDNB 206	WF-62	30 VAR	–	PDNB 206
	PDN 306	2 x 6306	VJ-PDNB 306	WF-72	30 VAR	FS 190	PDNB 306
35	PDN 207	2 x 6207	VJ-PDNB 207	WF-72	35 VAR	–	PDNB 207
	PDN 307	2 x 6307	VJ-PDNB 307	WF-80	35 VAR	FS 190	PDNB 307
40	PDN 208	2 x 6208	VJ-PDNB 208	WF-80	40 VAR	–	PDNB 208
	PDN 308	2 x 6308	VJ-PDNB 308	WF-90	40 VAR	FS 190	PDNB 308
45	PDN 309	2 x 6309	VJ-PDNB 309	WF-100	45 VAR	FS 190	PDNB 309
50	PDN 210	2 x 6210	VJ-PDNB 210	WF-90	50 VAR	–	PDNB 210
	PDN 310	2 x 6310	VJ-PDNB 310	WF-110	50 VAR	FS 260	PDNB 310
55	PDN 211	2 x 6211	VJ-PDNB 211	WF-100	55 VAR	–	PDNB 211
	PDN 311	2 x 6311	VJ-PDNB 311	WF-120	55 VAR	FS 260	PDNB 311
60	PDN 212	2 x 6212	VJ-PDNB 212	WF-110	60 VAR	–	PDNB 212
	PDN 312	2 x 6312	VJ-PDNB 312	WF-130	60 VAR	FS 260	PDNB 312
65	PDN 313	2 x 6313	VJ-PDNB 313	WF-140	65 VAR	FS 260	PDNB 313
70	PDN 214	2 x 6214	VJ-PDNB 214	WF-125	70 VAR	–	PDNB 214
	PDN 314	2 x 6314	VJ-PDNB 314	WF-150	70 VAR	FS 330	PDNB 314
75	PDN 215	2 x 6215	VJ-PDNB 215	WF-130	75 VAR	–	PDNB 215
	PDN 315	2 x 6315	VJ-PDNB 315	WF-160	75 VAR	FS 330	PDNB 315
80	PDN 216	2 x 6216	VJ-PDNB 216	WF-140	80 VAR	–	PDNB 216
	PDN 316	2 x 6316	VJ-PDNB 316	WF-170	80 VAR	FS 330	PDNB 316

¹⁾ For details about the components supplied, refer to the section *Ordering information* on page 570.

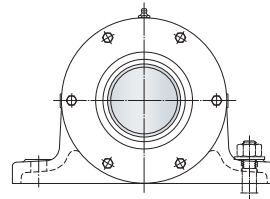
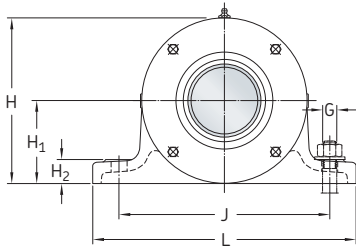

Sizes up to and including 211 and 309

Sizes from 212 and 310

Shaft diameter d_a	Dimensions Housing																Mass Housing	Unit	
	A	A ₁	A ₂	A ₃	A ₄	D _a	H	H ₁	H ₂	J	J ₁	L	N	G	G	G ₁			
mm	mm																in.	–	kg
25	202	146,5	35	40,5	7	62	95	50	16	120	135	155	12	10	3/8	G ¹ / ₈	5,1	7	
30	197	147,5	35	37,5	7	62	95	50	16	120	135	155	12	10	3/8	G ¹ / ₈	5,1	7,4	
	226	171,5	40	45	7	72	100	50	18	130	150	160	15	12	1/2	G ¹ / ₈	6,5	9,6	
35	227	173,5	40	45	7	72	100	50	18	130	150	160	15	12	1/2	G ¹ / ₈	6,5	10	
	260	195,5	45	49,5	8	80	116	60	18	150	175	190	15	12	1/2	G ¹ / ₈	9,1	13,5	
40	259	198,5	45	49,5	8	80	116	60	18	150	175	190	15	12	1/2	G ¹ / ₈	9,3	14,5	
	315	255,5	52	53	10	90	121	60	20	150	225	190	15	12	1/2	G ¹ / ₈	12,5	19,5	
45	360	279,5	52	63	10	100	137	70	22	170	250	210	15	12	1/2	G ¹ / ₈	15	24,5	
50	314	258,5	52	52	10	90	121	60	20	150	225	190	15	12	1/2	G ¹ / ₈	12,5	22,5	
	377	311,5	60	59	10	110	142	70	25	170	275	210	15	12	1/2	G ¹ / ₈	18	29,5	
55	356	283,5	52	60,5	10	100	137	70	22	170	250	210	15	12	1/2	G ¹ / ₈	15	27,5	
	422	335,5	60	69	10	120	158	80	25	210	300	260	19	16	5/8	G ¹ / ₈	23	39,5	
60	376	316,5	60	58	10	110	142	70	25	170	275	210	15	12	1/2	G ¹ / ₈	18	33	
	460	383,5	70	68	10	130	165	80	25	210	340	260	19	16	5/8	G ¹ / ₈	32,5	52,5	
65	492	402,5	70	74	11	140	185	95	25	230	360	280	19	16	5/8	G ¹ / ₄	32	57	
70	459	390,5	70	69	10	125	165	80	25	210	340	260	19	16	5/8	G ¹ / ₈	34,5	60,5	
	512	420,5	70	76	11	150	190	95	25	230	380	290	19	16	5/8	G ¹ / ₄	38	68,5	
75	459	389,5	70	69	10	130	165	80	25	210	340	260	19	16	5/8	G ¹ / ₈	32	62	
	547	448,5	80	83,5	12	160	200	100	30	260	400	320	19	16	5/8	G ¹ / ₄	43,5	80,5	
80	493	409,5	70	76	11	140	185	95	25	230	360	280	19	16	5/8	G ¹ / ₄	31	67	
	556	466,5	80	78	12	170	220	112	30	260	420	320	19	16	5/8	G ¹ / ₄	49,5	92	

12.1

12.1 Two-bearing housings in the PDN series

d_a 85 – 120 mm

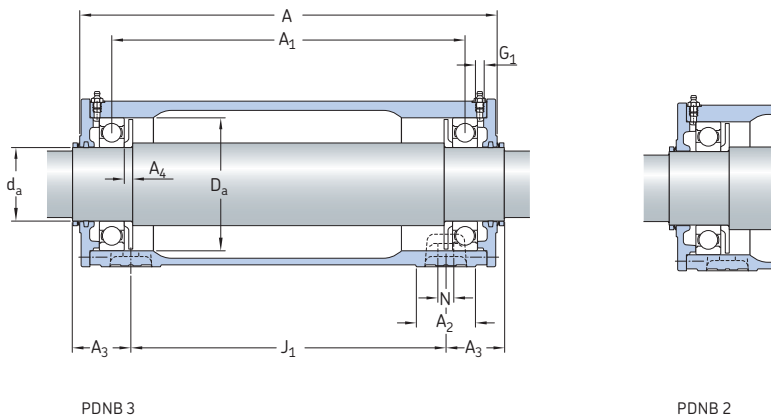

Shaft diameter	Housing Designation ¹⁾	Appropriate parts		Wave spring washer	Spare parts		Unit Designation ¹⁾
		Bearings	Shaft		V-ring	Felt strip	
d_a							
mm	-	-			-	-	
85	PDN 317	2 x 6317	VJ-PDNB 317	-	85 VAR	FS 330	PDNB 317
90	PDN 218	2 x 6218	VJ-PDNB 218	WF-160	90 VAR	-	PDNB 218
	PDN 318	2 x 6318	VJ-PDNB 318	-	90 VAR	FS 370	PDNB 318
95	PDN 319	2 x 6319	VJ-PDNB 319	-	95 VAR	FS 370	PDNB 319
100	PDN 220	2 x 6220	VJ-PDNB 220	-	100 VAR	-	PDNB 220
	PDN 320	2 x 6320	VJ-PDNB 320	-	100 VAR	FS 460	PDNB 320
110	PDN 222	2 x 6222	VJ-PDNB 222	-	110 VAR	-	PDNB 222
	PDN 322	2 x 6322	VJ-PDNB 322	-	110 VAR	FS 460	PDNB 322
120	PDN 224	2 x 6224	VJ-PDNB 224	-	120 VAR	-	PDNB 224
	PDN 324	2 x 6324	VJ-PDNB 324	-	120 VAR	FS 460	PDNB 324

¹⁾ For details about the components supplied, refer to the section *Ordering information* on page 570.

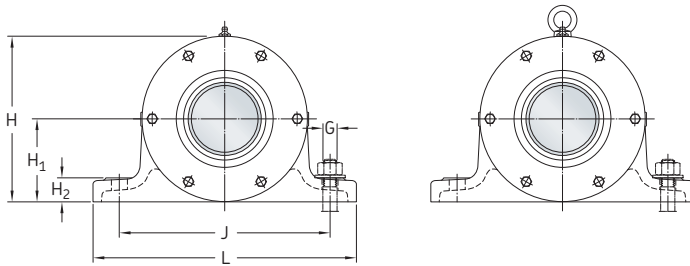

Sizes 224, and 320 and above (with M10 eye bolt)

Shaft diameter d_a	Dimensions Housing																Mass Housing	Unit
	A	A ₁	A ₂	A ₃	A ₄	D _a	H	H ₁	H ₂	J	J ₁	L	N	G	G	G ₁		
mm	mm															in.	-	kg
85	590	486	80	85	12	180	225	112	30	290	440	350	19	16	5/8	G ¹ / ₄	61	114
90	543	455,5	80	81	12	160	200	100	30	260	400	320	19	16	5/8	G ¹ / ₄	42,5	96,5
	605	510	85	82,5	11	190	230	112	30	290	460	350	19	16	5/8	G ¹ / ₄	71	134
95	648	540	90	94	13	200	253	125	36	320	480	400	24	20	3/4	G ¹ / ₄	82,5	156
100	588	493	80	83,5	12	180	225	112	30	290	440	350	19	16	5/8	G ¹ / ₄	60	130
	673	570	95	96,5	11,5	215	264	130	40	320	500	400	24	20	3/4	G ¹ / ₄	92,5	177
110	634	547	90	88	13	200	253	125	36	320	480	400	24	20	3/4	G ¹ / ₄	81	176
	686	580	95	94,5	10	240	296	150	40	380	520	450	28	24	1	G ¹ / ₄	115	226
120	672	577	95	97	11,5	215	264	130	40	320	500	400	24	20	3/4	G ¹ / ₄	90	207
	707	600	100	96	11,5	260	322	160	40	410	538	500	35	30	1 ¹ / ₄	G ¹ / ₄	135	276

12.2 Two-bearing housings in the PDP series

d_a 70 – 120 mm

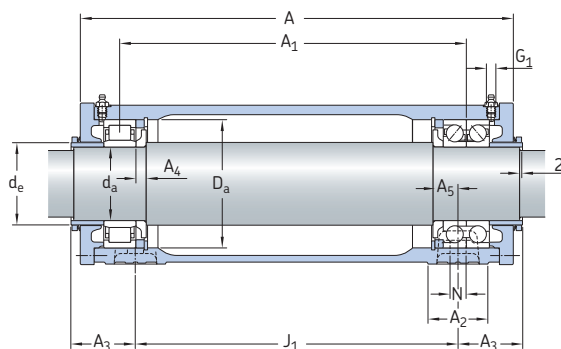

Shaft diameter d_a	Housing Designation ¹⁾	Appropriate parts		Shaft	V-ring	Unit Designation ¹⁾	Dimensions Housing	
		Bearings in the locating position	Bearing in the non-locating position				A	A_1
mm	-	-	-	-	-	-	mm	
70	PDP 214	2 x 7214 BECBP	NU 2214 ECP	VJ-PDPF 2214	80 VAR	PDPF 2214	459	376,5
80	PDP 216	2 x 7216 BECBP	NU 2216 ECP	VJ-PDPF 2216	90 VAR	PDPF 2216	493	394,5
90	PDP 218	2 x 7218 BECBP	NU 2218 ECP	VJ-PDPF 2218	100 VAR	PDPF 2218	543	437
100	PDP 220	2 x 7220 BECBP	NU 2220 ECP	VJ-PDPF 2220	110 VAR	PDPF 2220	585	470
110	PDP 222	2 x 7222 BECBP	NU 2222 ECP	VJ-PDPF 2222	120 VAR	PDPF 2222	634	520,5
120	PDP 224	2 x 7224 BCBM	NU 2224 ECP	VJ-PDPF 2224	130 VAR	PDPF 2224	672	548

¹⁾ For details about the components supplied, refer to the section *Ordering information* on page 570.

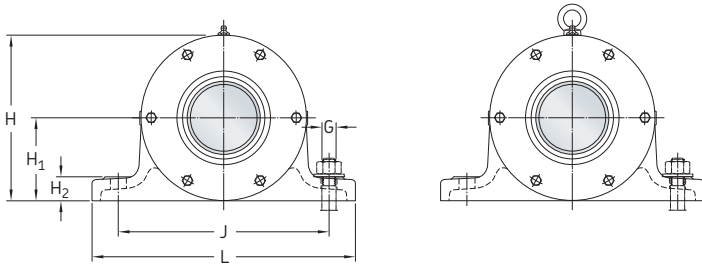

Size 224 (with M10 eye bolt)

Shaft diameter d_a	Dimensions Housing																Mass	
	A_2	A_3	A_4	A_5	d_e	D_a	H	H_1	H_2	J	J_1	L	N	G	G	G_1	Housing	Unit
mm	mm													in.	-	kg		
70	70	69	10	20	79	125	165	80	25	210	340	260	19	16	5/8	G ¹ / ₈	35	63
80	70	76	11	24,5	90	140	185	95	25	230	360	280	19	16	5/8	G ¹ / ₄	32	70,5
90	80	81	12	28,5	100	160	200	100	30	260	400	320	19	16	5/8	G ¹ / ₄	43,5	100
100	80	83,5	12	36,5	112	180	225	112	30	290	440	350	19	16	5/8	G ¹ / ₄	61,5	137
110	90	88	13	36,5	122	200	253	125	36	320	480	400	24	20	3/4	G ¹ / ₄	82,5	185
120	95	97	11,5	33	132	215	264	130	40	320	500	400	24	20	3/4	G ¹ / ₄	92	219

12.3 Two-bearing housings in the PDR series

d_a 75 – 120 mm

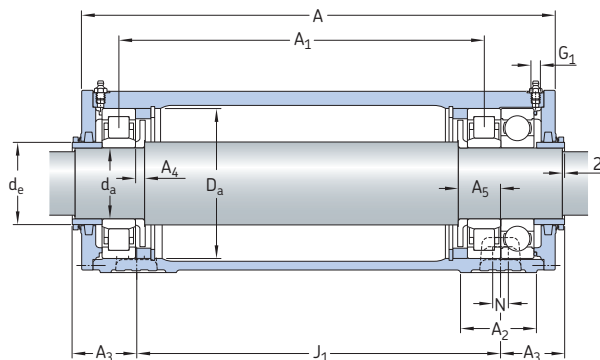

Shaft diameter d_a	Housing Designation ¹⁾	Appropriate parts		Shaft	Spare parts		Unit Designation ¹⁾
		Bearings in the locating position	Bearing in the non-locating position		V-ring	Felt strip	
mm	-	-	-	-	-	-	-
75	PDR 315	NU 315 ECP + 6315/C3	NU 315 ECP	VJ-PDRJ 315	90 VAR	FS 370	PDRJ 315
80	PDR 316	NU 316 ECP + 6316/C3	NU 316 ECP	VJ-PDRJ 316	95 VAR	FS 370	PDRJ 316
85	PDR 317	NU 317 ECP + 6317/C3	NU 317 ECP	VJ-PDRJ 317	100 VAR	FS 460	PDRJ 317
90	PDR 318	NU 318 ECP + 6318/C3	NU 318 ECP	VJ-PDRJ 318	100 VAR	FS 460	PDRJ 318
95	PDR 319	NU 319 ECP + 6319/C3	NU 319 ECP	VJ-PDRJ 319	110 VAR	FS 460	PDRJ 319
100	PDR 320	NU 320 ECP + 6320/C3	NU 320 ECP	VJ-PDRJ 320	120 VAR	FS 460	PDRJ 320
110	PDR 322	NU 322 ECP + 6322/C3	NU 322 ECP	VJ-PDRJ 322	130 VAR	FS 510	PDRJ 322
120	PDR 324	NU 324 ECP + 6324/C3	NU 324 ECP	VJ-PDRJ 324	140 VAR	FS 680	PDRJ 324

¹⁾ For details about the components supplied, refer to the section *Ordering information* on page 570.

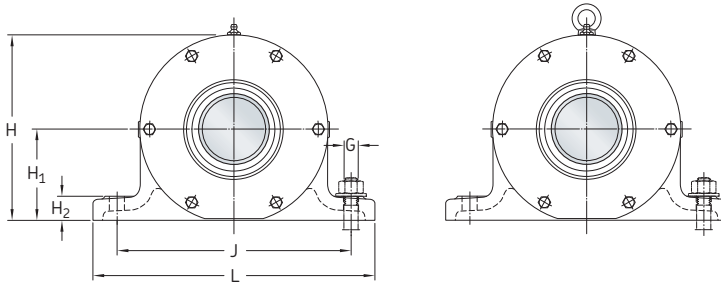

Size 320 and above (with M10 eye bolt)

Shaft diameter d_a	Dimensions Housing																Mass Housing Unit				
	A	A ₁	A ₂	A ₃	A ₄	A ₅	d _e	D _a	H	H ₁	H ₂	J	J ₁	L	N	G	G	G ₁	in.	-	kg
75	531	414	80	75,5	12	42	90	160	200	100	30	260	400	320	19	16	5/8	G ^{1/4}	45	-	85,5
80	552	430	80	76	12	46	95	170	220	112	30	260	420	320	19	16	5/8	G ^{1/4}	51	-	98,5
85	585	446	80	82,5	12	50	100	180	225	112	30	290	440	350	19	16	5/8	G ^{1/4}	62,5	-	120
90	603	468	85	81,5	11	50	105	190	230	112	30	290	460	350	19	16	5/8	G ^{1/4}	72	-	142
95	632	496	90	87,5	13	50	110	200	253	125	36	320	480	400	24	20	3/4	G ^{1/4}	84	-	164
100	671	524	95	97	11,5	46,5	120	215	264	130	40	320	500	400	24	20	3/4	G ^{1/4}	94	-	187
110	684	531	95	93,5	10	54,5	130	240	296	150	40	380	520	450	28	24	1	G ^{1/4}	117	-	240
120	705	546	100	95	11,5	62,5	140	260	322	160	40	410	538	500	35	30	1 1/4	G ^{1/4}	137	-	289

12.3

12.4 Shafts for two-bearing housings in the PDN 2 series

d_a 30 – 120 mm

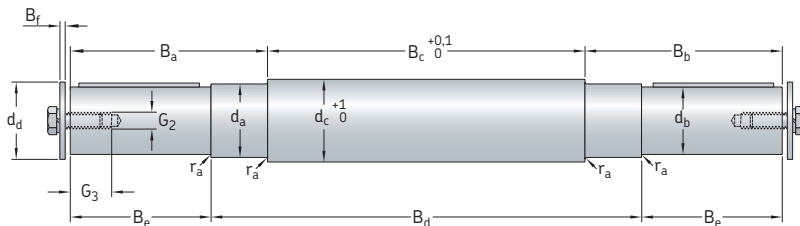

Dimensions Shaft

d_a	d_b	d_c	d_d	B_a	B_b	B_c	B_d	B_e	B_f	r_a	G_2	G_3
mm												
30	24	39	32	97	95,5	117,5	210	50	4	0,8	10	27
35	28	44	36	109,5	108	142,5	240	60	4	1,2	10	27
40	32	49	40	135,5	134	164,5	274	80	5	1,2	12	30
50	42	59	50	166	164,5	218,5	329	110	6	1,6	16	36
55	48	64	63	175	173,5	242,5	371	110	6	1,6	16	40
60	48	69	63	169	167,5	274,5	391	110	6	1,6	16	40
70	60	79	70	206,5	205	346,5	478	140	6	1,6	16	40
75	65	84	78	207,5	206	344,5	478	140	6	1,6	20	46
80	70	89	90	216	214,5	361,5	512	140	6	1,6	20	46
90	80	104	100	251	249,5	401,5	562	170	8	1,6	20	46
100	90	114	105	256	256	435	607	170	8	2,5	24	52
110	100	124	115	296,5	296,5	483	656	210	8	2,5	24	52
120	110	134	132	300	300	514	694	210	12	2,5	30	60

Shaft diameter d_a	Appropriate parts		Shaft	Shaft keys to ISO 773	Mass Shaft only
	Housing	Bearings			
mm	–				kg
30	PDN 206	2 x 6206	VJ-PDNB 206	8x7x40	1,8
35	PDN 207	2 x 6207	VJ-PDNB 207	8x7x40	2,85
40	PDN 208	2 x 6208	VJ-PDNB 208	10x8x63	4,25
50	PDN 210	2 x 6210	VJ-PDNB 210	12x8x80	7,65
55	PDN 211	2 x 6211	VJ-PDNB 211	14x9x80	10,5
60	PDN 212	2 x 6212	VJ-PDNB 212	14x9x80	13
70	PDN 214	2 x 6214	VJ-PDNB 214	18x11x100	23
75	PDN 215	2 x 6215	VJ-PDNB 215	18x11x100	26,5
80	PDN 216	2 x 6216	VJ-PDNB 216	20x12x100	31,5
90	PDN 218	2 x 6218	VJ-PDNB 218	22x14x140	47,5
100	PDN 220	2 x 6220	VJ-PDNB 220	25x14x140	61
110	PDN 222	2 x 6222	VJ-PDNB 222	28x16x180	83
120	PDN 224	2 x 6224	VJ-PDNB 224	28x16x180	102

Shaft diameter d_a	Appropriate parts		Shaft	Shaft keys to ISO 773	Mass Shaft only
	Housing	Bearings			
mm	–				kg
25	PDN 305	2 x 6305	VJ-PDNB 305	6x6x32	1,4
30	PDN 306	2 x 6306	VJ-PDNB 306	8x7x40	2,2
35	PDN 307	2 x 6307	VJ-PDNB 307	8x7x40	3,35
40	PDN 308	2 x 6308	VJ-PDNB 308	10x8x63	5,25
45	PDN 309	2 x 6309	VJ-PDNB 309	10x8x63	7,3
50	PDN 310	2 x 6310	VJ-PDNB 310	12x8x80	9,85
55	PDN 311	2 x 6311	VJ-PDNB 311	14x9x80	13
60	PDN 312	2 x 6312	VJ-PDNB 312	14x9x80	15,5
65	PDN 313	2 x 6313	VJ-PDNB 313	16x10x80	19,5
70	PDN 314	2 x 6314	VJ-PDNB 314	18x11x100	25
75	PDN 315	2 x 6315	VJ-PDNB 315	18x11x100	30
80	PDN 316	2 x 6316	VJ-PDNB 316	20x12x100	34,5
85	PDN 317	2 x 6317	VJ-PDNB 317	20x12x100	43
90	PDN 318	2 x 6318	VJ-PDNB 318	22x14x140	51
95	PDN 319	2 x 6319	VJ-PDNB 319	22x14x140	59,5
100	PDN 320	2 x 6320	VJ-PDNB 320	25x14x140	67,5
110	PDN 322	2 x 6322	VJ-PDNB 322	28x16x180	87,5
120	PDN 324	2 x 6324	VJ-PDNB 324	28x16x180	106

Shaft diameter d_a	Appropriate parts			Shaft	Shaft keys to ISO 773	Mass Shaft only
	Housing	Bearings in the locating position	Bearing in the non-locating position			
mm	–					kg
70	PDP 214	2 x 7214 BECBP	NU 2214 ECP	VJ-PDPF 2214	18x11x100	23
80	PDP 216	2 x 7216 BECBP	NU 2216 ECP	VJ-PDPF 2216	20x12x100	32,5
90	PDP 218	2 x 7218 BECBP	NU 2218 ECP	VJ-PDPF 2218	22x14x140	46,5
100	PDP 220	2 x 7220 BECBP	NU 2220 ECP	VJ-PDPF 2220	25x14x140	60,5
110	PDP 222	2 x 7222 BECBP	NU 2222 ECP	VJ-PDPF 2222	28x16x180	82
120	PDP 224	2 x 7224 BCBM	NU 2224 ECP	VJ-PDPF 2224	28x16x180	101

Shaft diameter d_a	Appropriate parts		Bearing in the non-locating position	Shaft	Shaft keys to ISO 773	Mass Shaft only
	Housing	Bearings in the locating position				
mm	–					kg
75	PDR 315	NU 315 ECP + 6315/C3	NU 315 ECP	VJ-PDRJ 315	18x11x100	29
80	PDR 316	NU 316 ECP + 6316/C3	NU 316 ECP	VJ-PDRJ 316	20x12x100	34
85	PDR 317	NU 317 ECP + 6317/C3	NU 317 ECP	VJ-PDRJ 317	20x12x100	42
90	PDR 318	NU 318 ECP + 6318/C3	NU 318 ECP	VJ-PDRJ 318	22x14x140	50,5
95	PDR 319	NU 319 ECP + 6319/C3	NU 319 ECP	VJ-PDRJ 319	22x14x140	58
100	PDR 320	NU 320 ECP + 6320/C3	NU 320 ECP	VJ-PDRJ 320	25x14x140	67
110	PDR 322	NU 322 ECP + 6322/C3	NU 322 ECP	VJ-PDRJ 322	28x16x180	86,5
120	PDR 324	NU 324 ECP + 6324/C3	NU 324 ECP	VJ-PDRJ 324	28x16x180	104